

BRRN

轴承座(承插型)

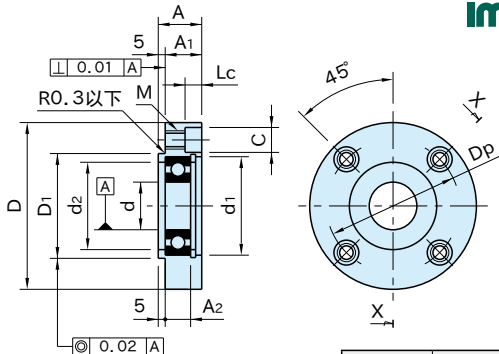

剖面 X-X

本体	轴承、扣环
S45C 无电解镀镍	钢铁

型号	轴承型号	d	D	D ₁ (g7)	A	A ₁	M	C	Lc	Dp	d ₁ (H7)	d ₂
BRRN2610	6000ZZ	10	55	32	16	11	M 5×0.8 (底孔 4.3)	8	4.4	40	26	22
BRRN3010	6200ZZ			36	17	12				44	30	
BRRN2812	6001ZZ	12	60	34	16	11				42	28	26
BRRN3212	6201ZZ			38	18	13	46	32				
BRRN3215	6002ZZ	15	65	17	12	M 6×1 (底孔 5.2)	9.5	5.4	48	32	28	
BRRN3515	6202ZZ			42	20				15	52	35	29
BRRN4220	6004ZZ	20	80	50	21				16	M 8×1.25 (底孔 6.8)	11	6.5
BRRN4720	6204ZZ			85	23	18	68	40				
BRRN4725	6005ZZ	25	90	54	21	16	M10×1.5 (底孔 8.5)	14	8.6			
BRRN5225	6205ZZ			60	25	20				78	52	45
BRRN5530	6006ZZ	30	100	62	23	18				80	55	48
BRRN6230	6206ZZ			105	70	26	21	88	62	55		

型号	A ₂	质量 (g)
BRRN2610	8	200
BRRN3010	9	230
BRRN2812	8	200
BRRN3212	10	290
BRRN3215	9	300
BRRN3515	11	380
BRRN4220	12	590
BRRN4720	14	760
BRRN4725	12	720
BRRN5225	15	1130
BRRN5530	13	990
BRRN6230	16	1300

使用示例及使用方法

- 使用示例及使用方法，注意事项等请参照“轴承固定座”。
- 安装方法请参照“轴承固定座的装拆方法”。