

ST-HTC-FM

侧推式肘节夹具

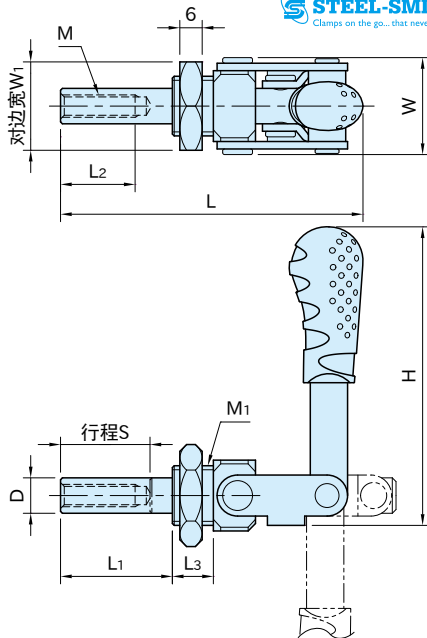

本体	突出轴	握把	螺栓、螺母	衬垫
SPCC 镀锌	S45C 镀锌	聚氯乙烯薄膜	SUM41 镀锌	氯丁二烯橡胶 (CR)

型 号	S	M	L ₁	D	L ₂	L	H	W	M ₁	L ₃	W ₁	保持力 (kN)	质量 (g)
ST-HTC190FM	24	M6×1	30	9.5	20	81	80	27.5	M16×2	11	24	0.5	130
ST-HTC350FM	36	M8×1.25	42	12	30	122	109	32.5	M20×1.5	15	30	1	290

附 件

- **ST-HTC190FM** :带衬垫螺栓(M6 全长46L 螺丝部33L)···1根、M6螺母···2个
- **ST-HTC350FM** :带衬垫螺栓(M8 全长66L 螺丝部50L)···1根、M8螺母···2个