

ST-HTC609

侧推式肘节夹具

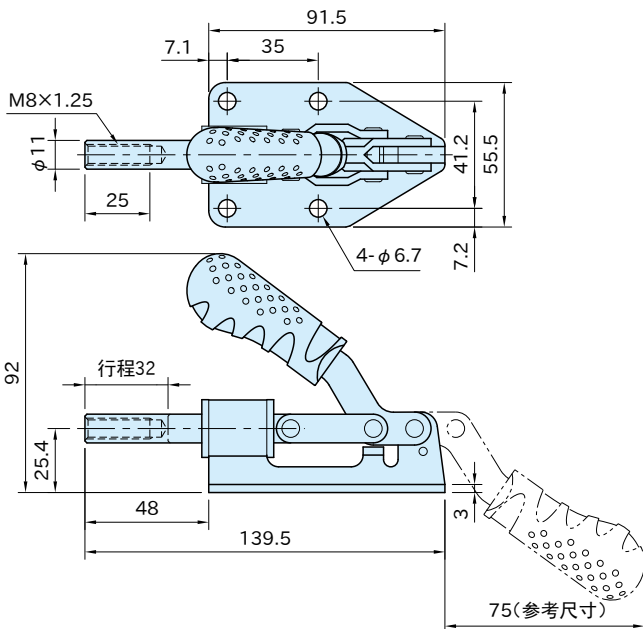

本体	底座	突出轴	握把	螺栓、螺母	衬垫
SPCC 镀锌	SPCC 黑色粉末烤漆	S45C 镀锌	聚氯乙烯薄膜	SUM41 镀锌	氯丁二烯橡胶 (CR)



型 号	压紧力 (kN)	质量 (g)
ST-HTC609PS	1.5	380

附 件

带衬垫螺栓(M8 全长66L 螺丝部50L)···1根
M8螺母···2个