

# ST-VTC201~210 垂直式肘节夹具

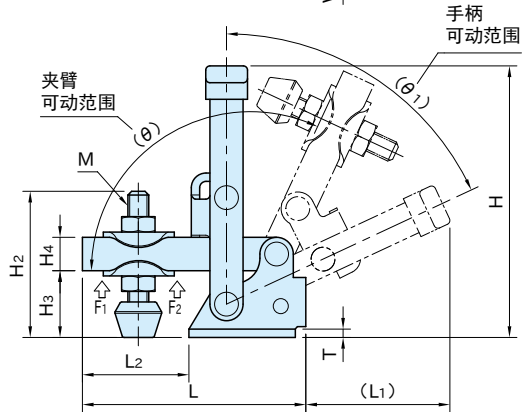
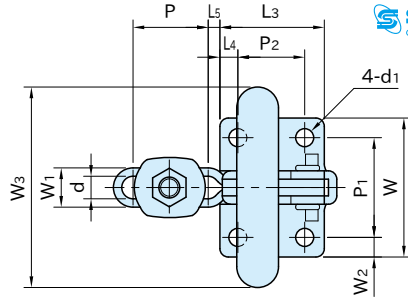

本体	夹臂	握把	螺栓、螺母	衬垫
SPCC 镀锌	SPCC(ST-VTC210TU:SPHD) 镀锌	聚氯乙烯薄膜	SUM41 镀锌	氯丁二烯橡胶 (CR)

型 号	$\theta$	$\theta_1$	M	H <sub>2</sub>	H <sub>3</sub>	d	P	L	H	W	L <sub>2</sub>	L <sub>3</sub>	T	d <sub>1</sub>
ST-VTC201TU	120°	65°	M 5	33	16	5.4	18	53.5	65	33	25.5	25	2	4.5
ST-VTC202TU	110°		M 6	46	23.9	6.4	30	76.1	80	39.3	45.8	25.5	3	5.5
ST-VTC202TUL	105°	70°				40	87.3	57						
ST-VTC207TU	110°	55°	M 8	66	31	8.6	37	100.2	114	44.6	57.5	35.1	7.1	
ST-VTC207TUL		60°			30		83	147.9			105			7.2
ST-VTC210TU		55°	M10	86	42	10	60	143.3	137	64.4	91	48.6	8.3	

型 号	P <sub>1</sub>	P <sub>2</sub>	W <sub>2</sub>	L <sub>4</sub>	L <sub>5</sub>	L <sub>1</sub>	H <sub>4</sub>	W <sub>1</sub>	W <sub>3</sub>	压紧力		质量 (g)
										F <sub>1</sub> (kN)	F <sub>2</sub> (kN)	
ST-VTC201TU	23.9	16	4.6	4.5	2.8	36	8	9.4	48	0.24	0.5	90
ST-VTC202TU	26.9	12.7	6.2	6.4	9.6	40	9.7	12.4	66	0.62	1	160
ST-VTC202TUL					10.8							
ST-VTC207TU	31.8	19.1	6.4	8	13.2	55	16	14.7	80	1	1.7	300
ST-VTC207TUL					14.7	60				0.7	1.5	340
ST-VTC210TU	45.2	31.8	9.6	8.4	23	55	20	18	140	1.4	2.7	590